

BEST PACKAGING



**Certified Refurbished
EAM MOSCA R-O-M-P 4
Arch Case Strapper**

Best Packaging Inc
(888) 930-BEST
BestPackaging.com

Certified Refurbished MOSCA R-O-M-P 4 Strapper

The ROMP-4 walk-up strapping machine has specific features to make quick work of bundling in fast-paced operations.

FEATURES

- DC brushless direct drive sealer eliminates all belts, chains, pulleys, sprockets, clutches and brakes.
- Dual access to strap coil dispenser for coil loading, and push-button strap threading simplifies coil changes to make it fast and convenient.
- Simple, external controls adjust strap tension.
- Two locking swivel casters and two fixed casters allowing for easy movement and positioning.
- Straps up to 40 packages per minute via foot-pedal or optional electronic photo-eye controls.
- Interlocked, hinged tabletop

The detail of the product(s), descriptions or specifications (for example weight, color, size, etc.) are only approximate values based upon product design, dimensions, and functionality as compared to the information shown on our website and/or any supplementary product information.

Certified Refurbished MOSCA R-O-M-P 4 Strapper

Machine Specifications			
	Width (Dim A)	Height (Dim B)	Cycle Time (min)
Sealing Area	23.6" (600 mm)	19.7" (500 mm)	Up to 40 Straps/ min
Strap Configuration	3/8" (6-9mm)		
Strap Type	Polypropylene		
Machine Dimensions	63.39" (1610 mm)	24.25" (616 mm)	50" (1270 mm)
Shipping Weight	500 lbs		
Electrical Requirements	110V/220V, 50/60 Hz, .5 KVA		
Air Requirements	4 CFM @ 90 psi		
Table Height	Standard Frame: 32.25"- 36.50" (820 mm - 925 mm)		

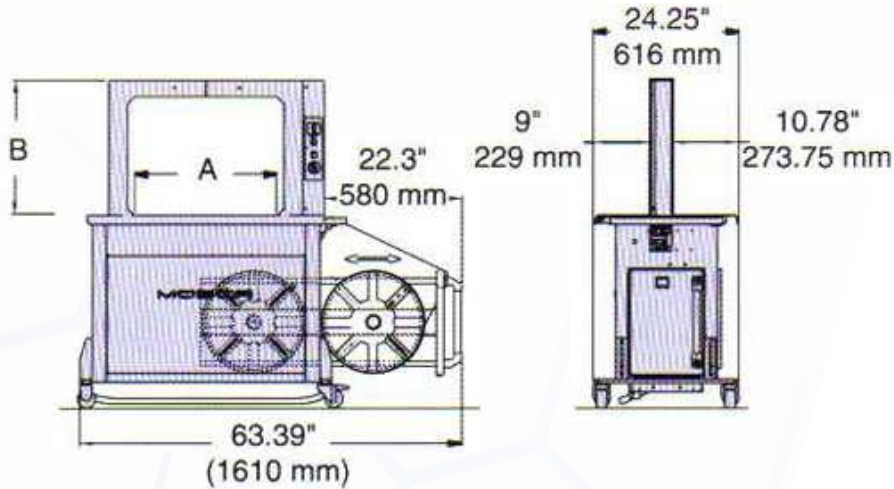

in a "standard model" of the representative product(s)/feature(s). There may be slight variations in the actual product documentation, including but not limited to product brochures and spec sheets.

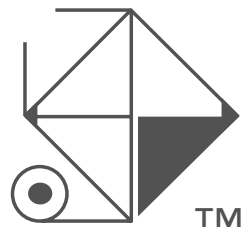



BEST PACKAGING®

WHY WE'RE THE BEST

Since 1997, we have been consulting, designing and implementing packaging solutions to offer the best for your operations. We represent a variety of equipment manufacturers, so as to ensure we're matching the right solution for your packaging needs. We only align ourselves with quality brands to make sure we are delivering the best value. It is our goal to provide the highest quality service to make your job easier and more productive.

Over 150 years of industrial experience, collectively.

We represent multiple brands and our analysis is unbiased. We can match the best systems with your needs based on the versatility of the job.

With preventative maintenance, operator training, and 24/7 support, we're with you every step of the way!

Steve Kudia, Owner of Best Packaging, serves on the ASTM committee. As part of a prestigious worldwide network of technical experts, he aims to make sure processes stay efficient by monitoring trends and educating customers on how they can improve their performance.

Equipment We Sell & Service

- Stretch Wrappers
- Shrink Wrappers
- Tray & Case Loaders
- Tray & Case Erectors
- Corrugated Case Formers
- Conveyors
- Palletizers
- Robotics
- Strappers & Banders
- Much, much more!

 @BestPackagingInc

 @Best_Packaging

 /Best-Packaging-Inc