

BEST PACKAGING



**Certified Refurbished
HeatSeal HS-115T
Combination Sealer & Tunnel**

Best Packaging Inc
(888) 930-BEST
BestPackaging.com

Certified Refurbished HeatSeal HS-115T Combination Sealer & Tunnel

Shrink Tunnel Features

- Heavy guage steel construction
- Automatic cool-down extends heating element life
- Heavy duty, high temperature mower blower
- High velocity turbo tunnel design
- High quality calrod heating element
- Special high quality silicone sealing pad
- Standard microprocessor Acc-U-Seal wire temp control
- U.L. listed control panel (*File No. E146586*)
- Film perforator
- Adjustable height wrapping platform
- Adjustable heat tunnel conveyor belt for bottom shrink control
- Heat sensitive cutoff switch
- Automatic cool-down extends heating element life



The detail of the product(s), descriptions or specifications (for example weight, color, size, etc.) are only approximate values based upon a “standard model” of the representative product(s)/feature(s). There may be slight variations in the actual product design, dimensions, and functionality as compared to the information shown on our website and/or any supplementary product documentation, including but not limited to product brochures and spec sheets.

Certified Refurbished HeatSeal HS-115T Combination Sealer & Tunnel

Specifications			
	Length	Width	Height
Shrink Chamber Dimensions	20" (508 mm)	14 1/2" (370 mm)	6" (150 mm)
L-Bar Seal Area	20" (508 mm)	15" (380 mm)	
Film Capacity	17" wide (430 mm)		
Working Height	35" 890 mm		
Conveyor Speed	0-20 FPM (0-0.10 m/s)		
Machine Weight	350 lbs (159 kg)		
Overall Machine Dimensions	72" (1829 mm)	27" (686 mm)	61" (150 mm)
Electrical Requirements	115 Volts, 20 Amps, Single Circuit w/ Ground		
Power Usage	Tunnel: 2,000 Watts, Conveyor Belt 500 Watts		

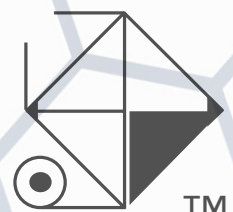
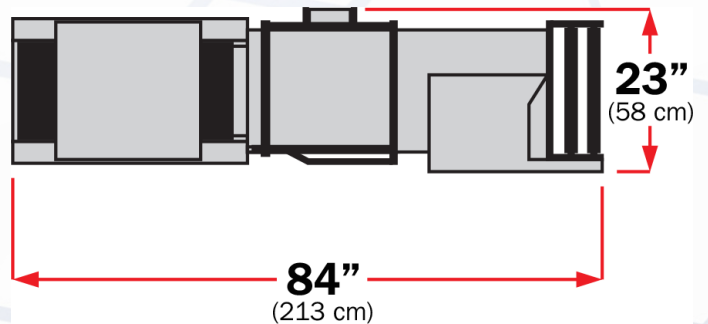
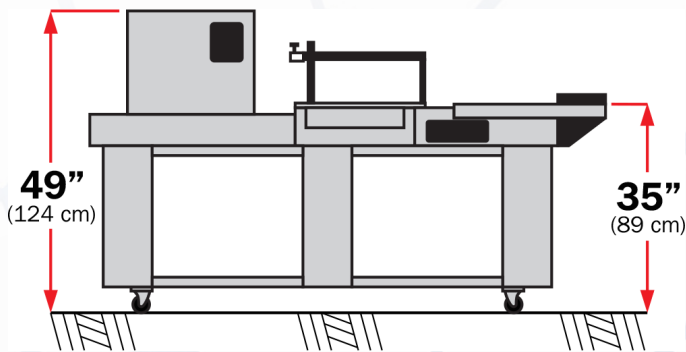

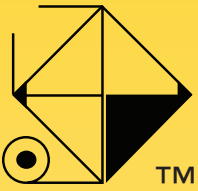

BEST PACKAGING®

WHY WE'RE THE BEST

Since 1997, we have been consulting, designing and implementing packaging solutions to offer the best for your operations. We represent a variety of equipment manufacturers, so as to ensure we're matching the right solution for your packaging needs. We only align ourselves with quality brands to make sure we are delivering the best value. It is our goal to provide the highest quality service to make your job easier and more productive.

Over 150 years of industrial experience, collectively.

We represent multiple brands and our analysis is unbiased. We can match the best systems with your needs based on the versatility of the job.

With preventative maintenance, operator training, and 24/7 support, we're with you every step of the way!

Steve Kudia, Owner of Best Packaging, serves on the ASTM committee. As part of a prestigious worldwide network of technical experts, he aims to make sure processes stay efficient by monitoring trends and educating customers on how they can improve their performance.

Equipment We Sell & Service

Stretch Wrappers

Shrink Wrappers

Tray and Case Loaders

Tray & Case Erectors

Corrugated Case Formers

Conveyors

Palletizers

Robotics

Strappers & Banders

Much, much more!



@BestPackagingInc



@Best_Packaging



/Best-Packaging-Inc