

# BEST PACKAGING

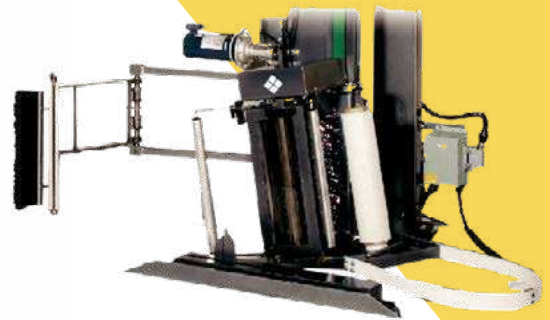

\*Automatic Cut &  
Wipe option included!  
(Shown Below)



**Certified Refurbished  
Cousins® 4100-35 FA  
Stretch Wrapper**

**Best Packaging Inc  
(888) 930-BEST  
BestPackaging.com**

## Certified Refurbished Cousins® 4100-35 FA Stretch Wrapper

The 4100-35 FA is a fully automatic free-standing rear mount pallet wrapper manufactured by Cousins. Its durable design and user-friendly controls set this stretch wrapper apart from the competition. The 1-12 RPM rotary arm features a soft start acceleration and final revolution deceleration and positive stop alignment. The unique film threading device orients the sticky side of the film against the pre-stretch rollers and the inside of the load. The variable pre-stretch ratio is adjusted using a sprocket change. Wrapping is fast and efficient using the single button auto wrap cycle start/pause.

### Standard Features:

- Power off-on-reset switch & power on indicator light
- Single button auto wrap cycle start/pause
- All structural steel construction
- Reinforce wrap control for mid-wrapping
- Rotary arm jog switch
- Emergency stop button
- Cycle pause for applying top sheets
- Film carriage lower & raise buttons
- Film clamp open/close button
- Film tension (force-to-load) control
- Separate film carriage raise & lower speed controls
- Variable rotary arm speed control
- Triple beam type auto load height sensing photo-eye, detects dark or shiny loads
- Selectable reduced bottom film force parameter for wrapping bottom of load
- Structural steel tube machine tower with sheet metal covers
- A-B-C wrap program selector with capability to input and store unique wrapping parameters for each program
- Electro-static powder coated paint finish
- Stack-light beacon indicates run, clear or fault conditions
- Rotary arm and carriage elevator dynamic braking system
- NEMA 12 control panel enclosure
- Rotary arm obstruction emergency safety stop sensor
- Dust tight slip ring assembly
- Non-proprietary UL/CSA approved components

The detail of the product(s), descriptions or specifications (for example weight, color, size, etc.) are only approximate values based upon a "standard model" of the representative product(s)/feature(s). There may be slight variations in the actual product design, dimensions, and functionality as compared to the information shown on our website and/or any supplementary product documentation, including but not limited to product brochures and spec sheets.

## Certified Refurbished Cousins® 4100-35 FA Stretch Wrapper

Specifications			
	Length	Width	Height
Maximum Load Size	50" (1270 mm)	50" (1270 mm)	86" (2184 mm)
Minimum Load Size	40" (1016 mm)	40" (1016 mm)	24" (610 mm)
Maximum Load Weight	Unlimited (floor supported)		
Production Speed	1-30 loads per hour*		
Rotary Arm	Double flange bearing support system Twin V-belt drive pulleys with belt tensioner 1-12 RPM rotational speed c/w soft start acceleration Final revolution deceleration and positive stop alignment ½ HP DC variable speed motor		
Film Carriage Elevator	½ HP AC variable speed motor Direct flat belt drive system		
Film Delivery System	Super Rapid Thread II™ 20" capacity pre-stretch film carriage ½ HP AC variable speed motor Fully electronic dynamic dancer corner compensation 33% - 313% fixed stretch capacity		
Pneumatic Requirements	3 CFM @ 80 PSI clean dry pneumatic supply required filter/regulator c/w guage & lock-out valve provided		
Electrical Requirements	115 Volts, 1 Phase, 60 Hz, 15 Amps		

\*Process rates will vary with load size, number of wraps & forklift load/unload time

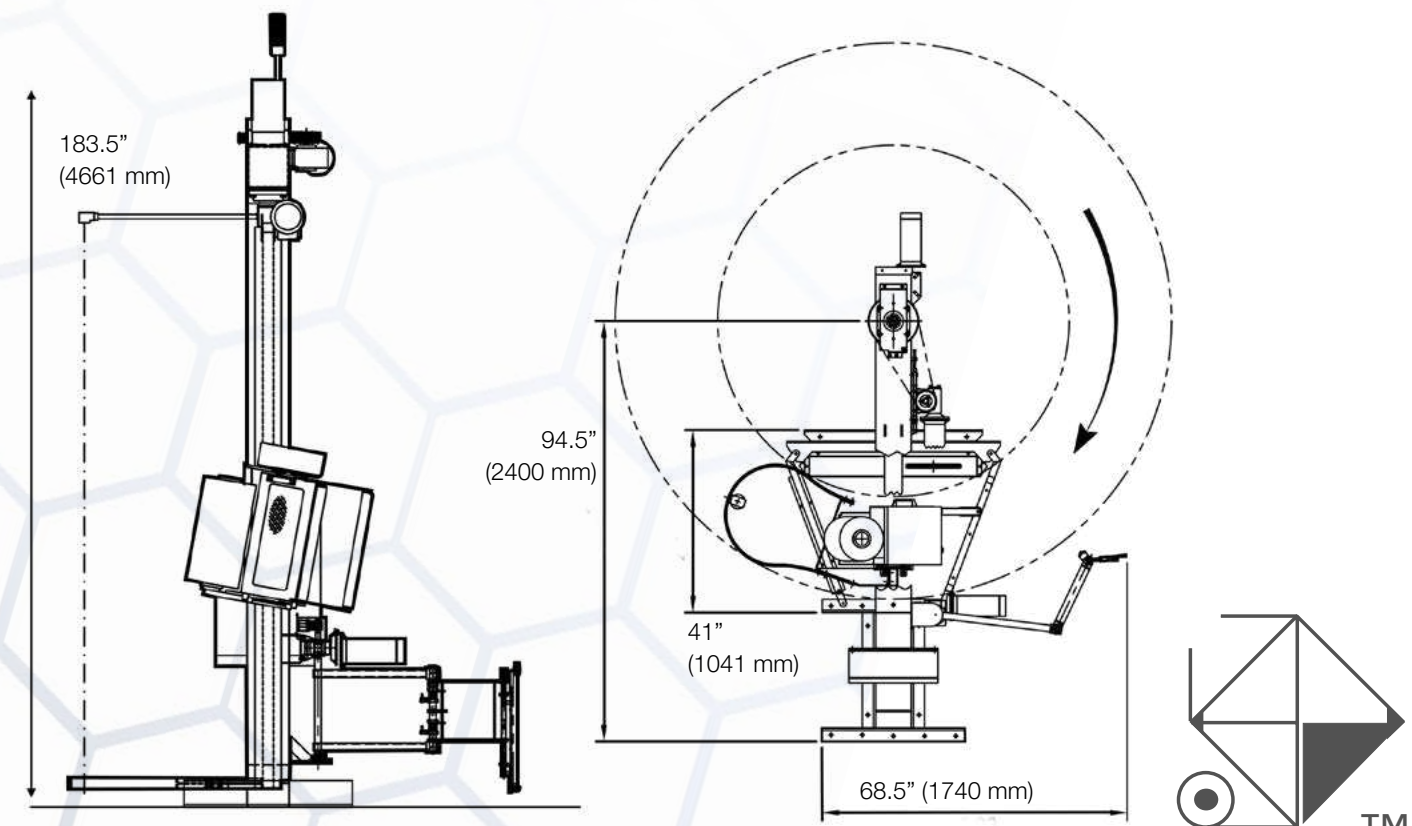

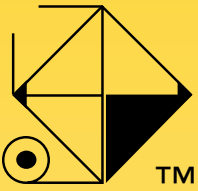

# BEST PACKAGING®

## WHY WE'RE THE BEST

Since 1997, we have been consulting, designing and implementing packaging solutions to offer the best for your operations. We represent a variety of equipment manufacturers, so as to ensure we're matching the right solution for your packaging needs. We only align ourselves with quality brands to make sure we are delivering the best value. It is our goal to provide the highest quality service to make your job easier and more productive.

Over 150 years of industrial experience, collectively.

We represent multiple brands and our analysis is unbiased. We can match the best systems with your needs based on the versatility of the job.

With preventative maintenance, operator training, and 24/7 support, we're with you every step of the way!

Steve Kudia, Owner of Best Packaging, serves on the ASTM committee. As part of a prestigious worldwide network of technical experts, he aims to make sure processes stay efficient by monitoring trends and educating customers on how they can improve their performance.

Equipment We Sell & Service

Stretch Wrappers

Shrink Wrappers

Tray and Case Loaders

Tray & Case Erectors

Corrugated Case Formers

Conveyors

Palletizers

Robotics

Strappers & Banders

Much, much more!



@BestPackagingInc



@Best\_Packaging



/Best-Packaging-Inc