

# BEST PACKAGING



**Certified Refurbished  
Wexxar Bel<sup>®</sup>  
Bel 252 Side Belt /  
Top-Bottom Case Taper**

---

**Best Packaging Inc  
(888) 930-BEST  
BestPackaging.com**

## Certified Refurbished Wexxar Bel<sup>®</sup>, Bel 252 Side Belt / Top-Bottom Case Taper

### CONSTRUCTION

The machine has a heavy-duty, paint-free, corrosion resistant, frame made of high tensile aluminum C-Beam extrusions, anodized after welding. Other materials: zinc plated steel, stainless steel, and engineering plastics, stainless steel fasteners.

### SNAP FOLDER SYSTEM

Wexxar Bel's design includes horizontal movements occurring at case-top level that tuck and fold the top flaps, ensuring operator safety by eliminating flap "kicker" arms.

### TAPE HEADS

DEKKA Model 22 recommended, with 2" tape width heads, quick loading feature, and center-pull tape guide system. Can be modified to fit DEKKA 23, with 3" tape width heads by request.

### DRIVE SYSTEM

*Uni-drive* synchronized side belt conveyor system powered by a single 1/2 H.P. TEFC motor and 3/4 H.P. rated gear reducer.

### DRIVE BELTS

3" *Leder* brand rough top continuous loop with finger splice join and v-rib backing.

### SAFETY PROVISIONS

- *Snap Folder* top flap folding system
- Conveyor drive and belt pulleys are fully guarded
- Magnetic motor starter switch prevents accidental restarts after a power interruption
- Potential hazards are warned with labels to ANSI standards

The detail of the product(s), descriptions or specifications (for example weight, color, size, etc.) are only approximate values based upon a "standard model" of the representative product(s)/feature(s). There may be slight variations in the actual product design, dimensions, and functionality as compared to the information shown on our website and/or any supplementary product documentation, including but not limited to product brochures and spec sheets.

## Certified Refurbished Wexxar Bel<sup>®</sup>, Bel 252 Side Belt / Top-Bottom Case Taper

Specifications			
	Length	Width	Height
Minimum Case Size	8" (203 mm)	6" (153 mm)	4.5" (114 mm)
Maximum Case Size	22" (559 mm)	15" (381 mm)	16" (406 mm)
Machine Dimensions	58" (1473 mm)	33" (838 mm)	53.3" (1353 mm)
Infeed/Outfeed Height (with adjustable leg extensions)			Minimum: 23.5" (597 mm) Maximum: 32" (813 mm)
Speed	Up to 25 cases /min.		
Shipping Weight	Approximately 650 lbs (295 kg.)		
Electrical Requirements	120 VAC, 10 A., 60 cycle, 1-phase NEMA 12, with magnetic motor starter switch		
Compressed Air Requirements	0.1 CF/cycle @ 80-90 PSI (6 bar)		

\*NOTE: Maximum case dimensions may not run simultaneously

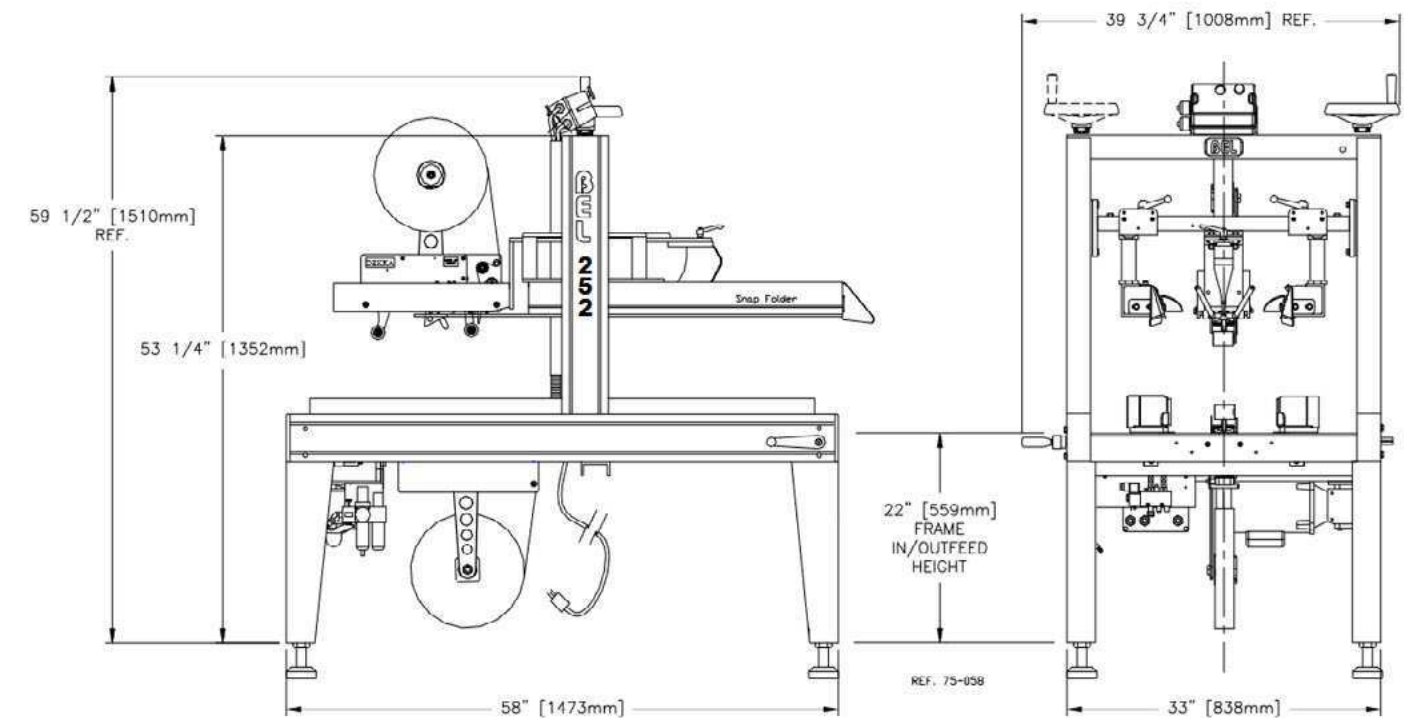

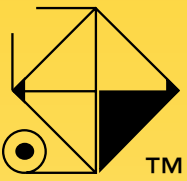

# BEST PACKAGING®

## WHY WE'RE THE BEST

Since 1997, we have been consulting, designing and implementing packaging solutions to offer the best for your operations. We represent a variety of equipment manufacturers, so as to ensure we're matching the right solution for your packaging needs. We only align ourselves with quality brands to make sure we are delivering the best value. It is our goal to provide the highest quality service to make your job easier and more productive.

Over 150 years of industrial experience, collectively.

We represent multiple brands and our analysis is unbiased. We can match the best systems with your needs based on the versatility of the job.

With preventative maintenance, operator training, and 24/7 support, we're with you every step of the way!

Steve Kudia, Owner of Best Packaging, serves on the ASTM committee. As part of a prestigious worldwide network of technical experts, he aims to make sure processes stay efficient by monitoring trends and educating customers on how they can improve their performance.

### Equipment We Sell & Service

- Stretch Wrappers
- Shrink Wrappers
- Tray and Case Loaders
- Tray & Case Erectors
- Corrugated Case Formers
- Conveyors
- Palletizers
- Robotics
- Strappers & Banders
- Much, much more!



@BestPackagingInc



@Best\_Packaging



/Best-Packaging-Inc